



CUBRO
NETWORK VISIBILITY

EUROPE'S LEADING POWER COMPANY SELECTS CUBRO'S OMNIA120 FOR NETWORK VISIBILITY ACROSS ITS INFRASTRUCTURE

CASE STUDY





CASE STUDY

EUROPEAN POWER COMPANY SELECTS CUBRO'S OMNIA120

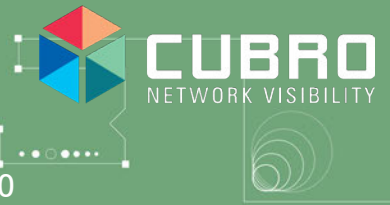

Industry » Enterprise

Technical Challenges

The customer was about to implement a new data centre with a Spine - Leaf architecture. This required all relevant network traffic to be forwarded to ExtraHop's Reveal (X) NDR platform, a Traffic Analysis Solution that features 2 x 25G full packet analysis interfaces and includes real time description of network traffic.

Case Study Summary

A new data centre deployment by one of the leading power companies in Europe created an additional requirement for enhancing the current network visibility. A trial offered by Cubro gave the customer the confidence that our solution perfectly suited the requirement and offered higher ROI. The customer deployed Cubro's advanced network packet broker, Omnia120 and Breakout boxes as part of the solution.

About the company

The customer is a leading power company in Europe and one of the largest producers of hydropower electricity. The company accounts for more than half of Austria's hydropower. The company is a large enterprise with approximately 3000 employees.

Lack of visibility due to a new data centre deployment

The customer was about to implement a new data centre with a Spine - Leaf architecture. This required all relevant network traffic to be forwarded to [ExtraHop's](#) Reveal (X) NDR platform, a Traffic Analysis Solution that features 2 x 25G full packet analysis interfaces and includes real time description of network traffic. The traffic for the Security Monitoring Solution is provided via mirror ports coming from all Leaf switches and in total there are 16 x 10G and 24 x 100G ports that need to be connected to ExtraHop.

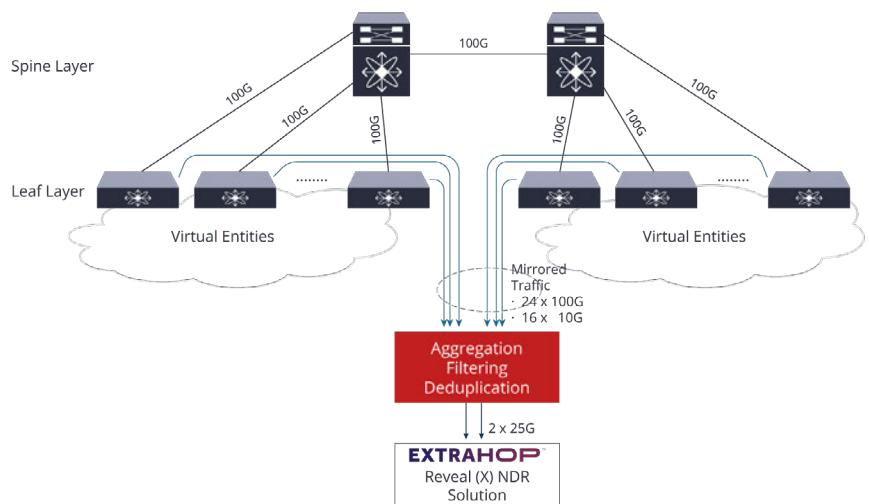

CASE STUDY

EUROPEAN POWER COMPANY SELECTS CUBRO'S OMNIA120

In addition to the EXA32100 and Omnia120, Cubro offered two units of Breakout Boxes. These breakout boxes add stability and simplicity to the solution. By using breakout boxes, it is easy to convert from LC to MTP connectors and vice versa.

The major technical challenges faced by the customer to get the complete visibility included:

- Aggregation Layer to combine 16 x 10G plus 24 x 100G to connect to 2 x 25G of the Security Monitoring Appliance.
- Drop (=filtering out) non required traffic so that it does not reach the Security Monitoring Appliance.
- Eliminate duplicate packets; as traffic is picked up from various mirror ports simultaneously the same packet is available several times which causes unnecessary load for the Security Monitoring Solution.

A two-step approach to get network visibility with Cubro Solution

Cubro offered a two-step processing approach consisting of EXA32100, Cubro's Advanced Packet Broker, that serves as an aggregation device for filtering and as a central connection point providing all interfaces from the network and also towards the Security Monitoring Appliance.

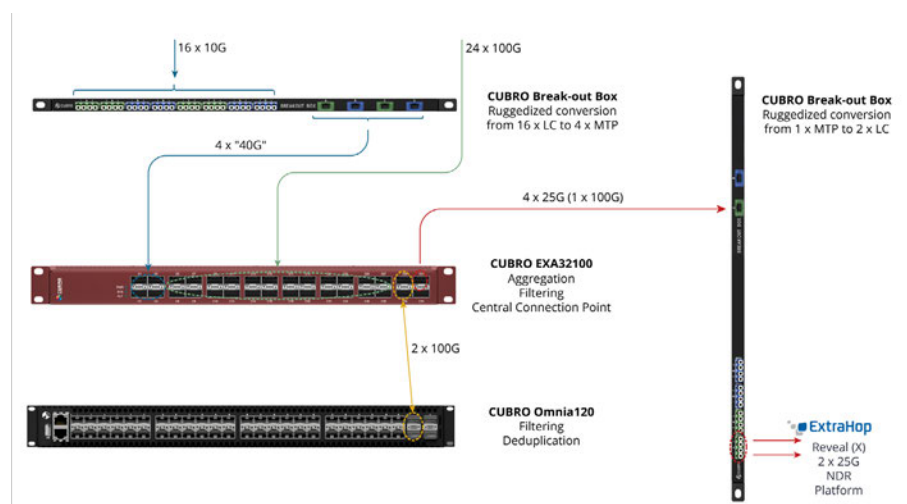

In the second step, the packets are forwarded to Omnia120 for high-performance deduplication to eliminate duplicate packets and to reduce the final load to the ExtraHop device.

In addition to the EXA32100 and Omnia120, Cubro offered two units of Breakout Boxes. These breakout boxes add stability and simplicity to the solution. By using breakout boxes, it is easy to convert from LC to MTP connectors and vice versa.



CASE STUDY

EUROPEAN POWER COMPANY SELECTS CUBRO'S OMNIA120

The customer preferred the solution offered by Cubro due to the superior technical capabilities, lower purchase price as well as lower maintenance costs compared to the competitors.

The connection is much more stable compared to the breakout cables that hang in the rack and are not ruggedized.

Due to the advanced filtering feature of Cubro's advanced network packet broker, the customer was able to optimize the security tool and increase its efficiency. The deduplication feature of Omnia120 reduced the traffic being sent to the security and resulted in a better collection of security data. Overall, the security tool was able to work more efficiently without any performance degradation.

The customer preferred the solution offered by Cubro due to the superior technical capabilities, lower purchase price as well as lower maintenance costs compared to the competitors.

The Operational and Business benefits

The major operational and business benefits of the solution offered by Cubro include:

- Removal of the blind spot from all network environments resulting in uninterrupted service and better performance
- Managed distribution of traffic to the security tool which increases the efficiency of the security tool
- Improved monitoring and security posture
- Reduced cost of monitoring and increase in ROI
- Excellent technical support