

Cubro and ClearTrail Joint Solution Highlights:

- ClearTrail Technologies offers powerful intelligence and investigation technologies for security agencies globally.
- ClearTrail's system processes data at multi 100Gbps speed, ingesting billions of transactions daily.
- Enables comprehensive analysis of encrypted & non-encrypted communication data, facilitating real-time decision-making.
- Helps agencies understand suspects' patterns-of-life behind activities and communications over the internet.
- Integrates seamlessly with Cubro Network TAPs and Advanced High-Speed Packet Brokers for enhanced network visibility and intelligence gathering.

Monitoring Communications in the Era of 'Data Gone Dark'

The communication landscape has rapidly transformed over the past two decades. Agencies around the world are dealing with increasingly organized, well-funded criminals who use the latest encryption technologies and smart devices to keep their activities concealed. Constant increase in encrypted internet communications leads to a variety of unique challenges in communication monitoring & analytics operations.

At the same time, the growing density, diversity, and complexity of communication networks calls for a comprehensive approach to analyze the communication data to be able to detect potential threats. Agencies today need adaptable systems that can enable them to answer complex questions hidden in volumes of network traffic.

"ClearTrail, in collaboration with Cubro, is committed to building the best-in-class real-time network traffic decoding and analysis technologies, that deliver actionable intelligence from communication data, rapidly and with ease."

From Complete Network Visibility to Actionable Intelligence

For over 22 years, ClearTrail Technologies has focused on creating powerful intelligence and investigation technologies for federal and state level security agencies across the globe. ClearTrail's system is capable of processing data at a speed of multi 100Gbps concurrently, ingesting billions of rows of transactions every day and retaining it for years in a data store ranging up to 100s of petabytes.

Besides comprehensive analysis of encrypted & non-encrypted communication data, the system also enables replay, visualization & analysis of decodable content, including text documents, voice calls and videos. The integrated text and media analytics capability enables rapid consumption of huge amounts of content and facilitates real-time decision-making.

ClearTrail enables the agency to solve high-tech crimes by helping them understand a suspect's pattern-of-life hidden behind their activities and communications over the internet, and identify the specific set of behaviors and movements associated with a particular entity over a given period to have a clear understanding of what activities were done and when.

In addition to monitoring the network traffic, it is imperative for the agencies to invest in

systems that can meet the increasing demands of rigorous technological innovations. ClearTrail's system can seamlessly integrate with Cubro Network TAPs and Advanced High-Speed Packet Brokers to access network traffic to monitor high speed communications taking place at different scales and over diverse platforms. These components are robust enough to handle the vast inflow of data and agile enough to adapt to the diverse data structures and protocols across different ISPs to take intelligence gathering to the next level.

Cubro Network TAPs

Key Highlights

- Traffic aggregation from different locations / links
- Filtering traffic based on more than 100K parallel filtering rules
- Deduplication of network packets
- Header removal for reduced payload
- Slicing of encrypted packets to discard irrelevant information

ClearTrail's System

ClearTrail's system acquires actionable intelligence by extracting IP Metadata from petabytes of digital payloads to identify threats in real-time and provide accurate and valuable insights to reveal patterns of communication.

ClearTrail provides the analyst with the capability to rapidly detect anomalies, predict future actions, and uncover potential risks/advanced threats and improved situational awareness such as terrorism, organized crime, and cyberattacks.

Key Highlights

- Monitoring targets/suspects
- Profiling persons-of-interest for their activities
- Assessing potential threats to refine strategies and allocate resources
- Providing 360-degree intelligence from disparate systems and datasets
- Detecting anomalies based on suspicious behavior
- Tracking of networks / locations

The Combined Power of Cubro x ClearTrail

ClearTrail's advanced Telecom Metadata Mining System, Target-based IP and Voice Analytics System, and Data Fusion System process and extract billions of metadata and other communication records per minute. In some cases, these figures can go up to 100+ billion records per day or more. This extensive and exhaustive process requires refined, balanced, and groomed traffic as an input for solution probes.

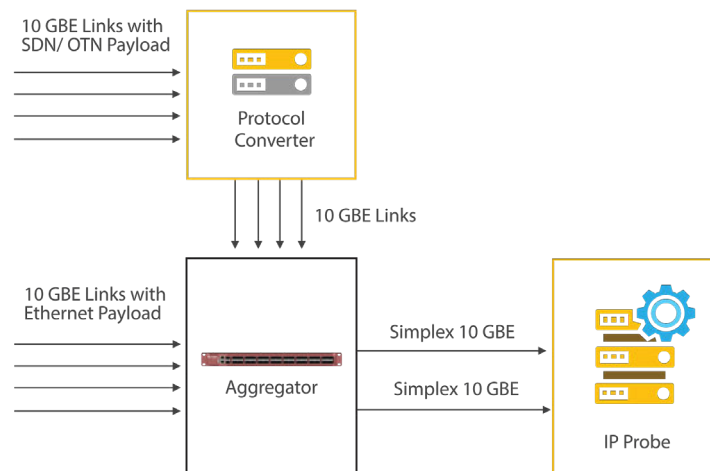

Cubro provides a robust series of NPBs and aggregators:

- By providing Generic Routing Encapsulation (GRE) it provides a private path for transporting packets through an otherwise public network by encapsulating (or tunnelling) the packets.
- Network traffic Aggregation to provide the aggregated traffic from multiple input links of different types such as 1G, 10G, 40G, 100G for consolidated optimized output for ClearTrail's advanced decoding probes.
- Link breakout for multiple 100G links as an input.
- Supporting port mirroring for duplicating the input traffic for metadata generation and analytics.
- Configurable port for high availability of traffic routing in case of failures.
- Defining and supporting load-balancing groups for output optimization.
- Providing and supporting NetFlow generation for in depth monitoring of traffic.
- Supporting deduplication, in result avoiding unwanted traffic load ingested to the probes and optimizing the input for ClearTrail's telecom data mining system.
- IP based filtering and blocking functionality support selection of specific IP group traffic for analytics.

Together, Cubro and ClearTrail's joint solution provides a solid digital intelligence foundation to accelerate your intelligence gathering missions.

To know more, please reach out to info@clear-trail.com or support@cubro.com

For more information please visit www.cubro.com.