



CUBRO
NETWORK VISIBILITY

1 LINK COPPER BYPASS TAP



```
01001011101
00010010001
00100100001
01001001010
```

DATA SHEET

Bypass TAP At a glance

Definition

A bypass switch (or bypass TAP) is a hardware device that provides a fail-safe access port for electrical links.

Advantages of Cubro 1 Link Copper Bypass TAP

- Increased reliability on critical network links
- Fail-safe inline protection
- High-speed switching
- LED indicators show power, speed, link, and activity status
- Tested and compatible with most of the monitoring devices
- Management via Web UI
- Bypass, TAP and patch panel modes

Product Overview



The Cubro Copper Bypass TAP for 10/100/1000 links is the perfect choice to protect sensitive data-links in case of electrical power and/or link problems. Usually, it is deployed together with a network security appliance such as an intrusion detection system (IDS) or an Intrusion prevention system (IPS). Whenever these security devices need to be rebooted or go offline for any reason, the Cubro Copper Bypass TAP will make sure that faulty or unavailable devices are bypassed so that data traffic will continue to flow.

In stand-alone mode, the Cubro Copper Bypass TAP will be able to offer secure and fast protection against electrical power failures and also against link failures. Whenever such a problem is detected the extremely fast switching relays will make sure that the link is closed.

Moreover, the Cubro Copper Bypass TAP can be controlled by an Web UI and REST interface to read-out the status of the Bypass and or to control it.

Standalone mode

In stand-alone mode, the Cubro Copper Bypass TAP is the perfect protection against power outage and also for device link failures. Super fast switching relays will close the live circuit to avoid data loss on the live link.

Traffic flow in normal mode

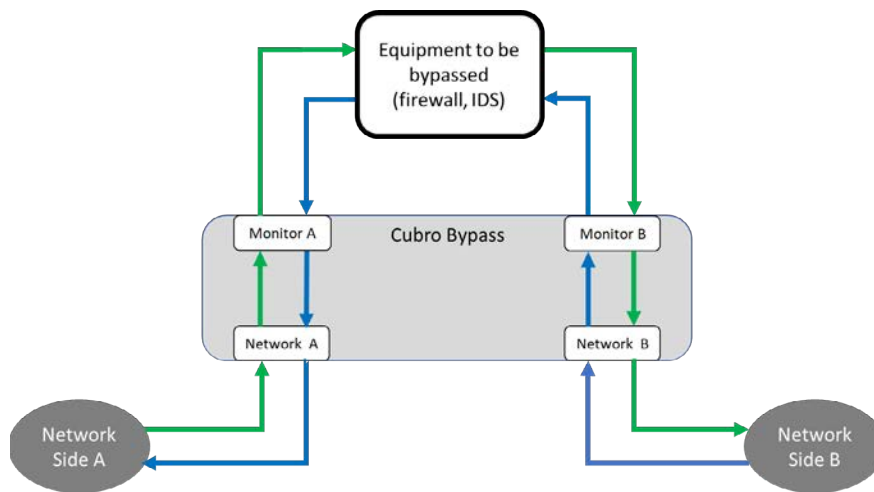

Traffic Flow in failure mode (electrical power and/or configurable triggers)

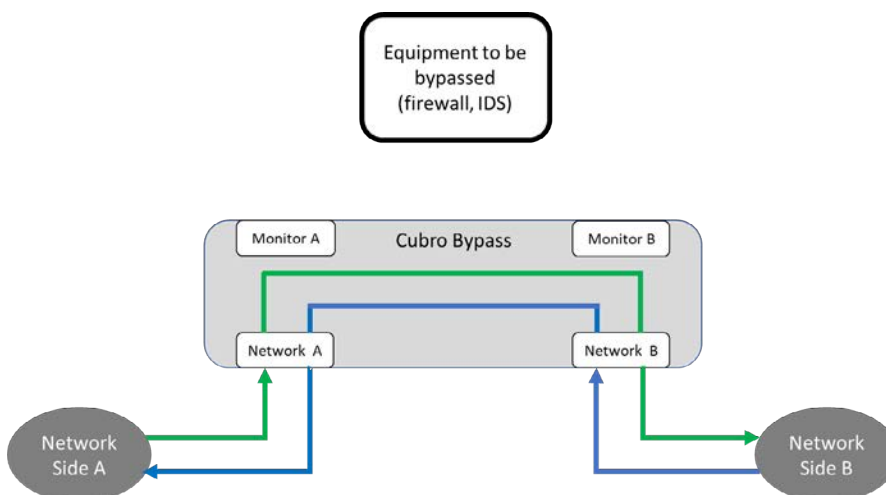

Together with Cubro Packetmaster EX Series

When the Cubro Copper Bypass TAP is used together with the Packetmaster EX family, it adds Heartbeat capabilities. Heartbeats generated by the Packetmaster will be sent through the monitor link and will also be received and analysed by the Packetmaster EX allowing to detect any failures of the bypassed devices.

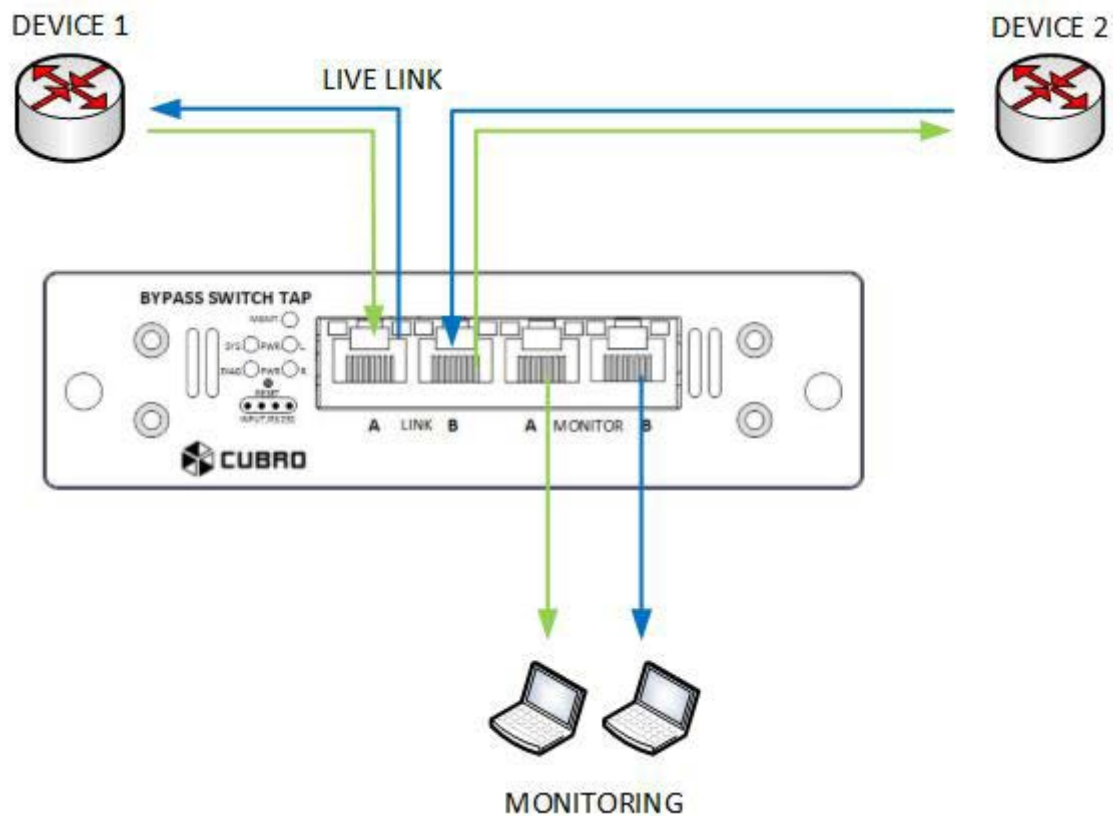

Specifications:

- Operating Temperature: -5°C to 55°C
- Storage Temperature: -10°C to 70°C
- Relative Humidity: 10% min, 95% max, non-condensing
- Input Power: 12V DC, 15W

Certifications:

- EMC Emissions: EN55022 (CISPR22) Class B, EN61000-3-2,-3
- EMC Immunity: Compliance to EN61000-4-2,3,4,5,6,8,11, EN55024,
- Safety Standards: UL60950-1, EN60950-1 approved
- Fully RoHS compliant

Product Capabilities / Features

Port	4 x 10/100/1000 MBit RJ 45 connector
Relay switching time	<2 ms
Easy use and operation	Straight-forward operation via remote connection
LED Indicators	LEDs on the front panel indicate power, link and activity status
Rugged 19" Housing	The unit is delivered in a rugged housing with precise connector labelling on the front panel.
Power	12 V DC dual (redundant) power supply
Options to activate the bypass	<ol style="list-style-type: none"> 1) via Ping 2) via REST 3) via GPIO 4) power fail 5) link loss on monitoring side 6) heartbeat loss (controlled by Packetmaster EX)
Management	Web UI

Ordering Information

Product Type & Number	Description
CBR.BYSW-Copper-1-1-R3	Copper Bypass TAP, 1 Link, RJ45 connector; 1/3 19" rackmount housing (rackmount kit not included)
CBR.RM19-3	Cubro 19" Rackmount Kit for 3x 1/3 19" units

For more information please check our website www.cubro.com